



NILOS

NILOS GmbH & Co. KG
Reisholzstr. 15
40721 Hilden • Germany
Phone: +49 2103 951-0
Fax: +49 2103 951-209
info@nilos.de
www.nilos.de



Belt Ripper

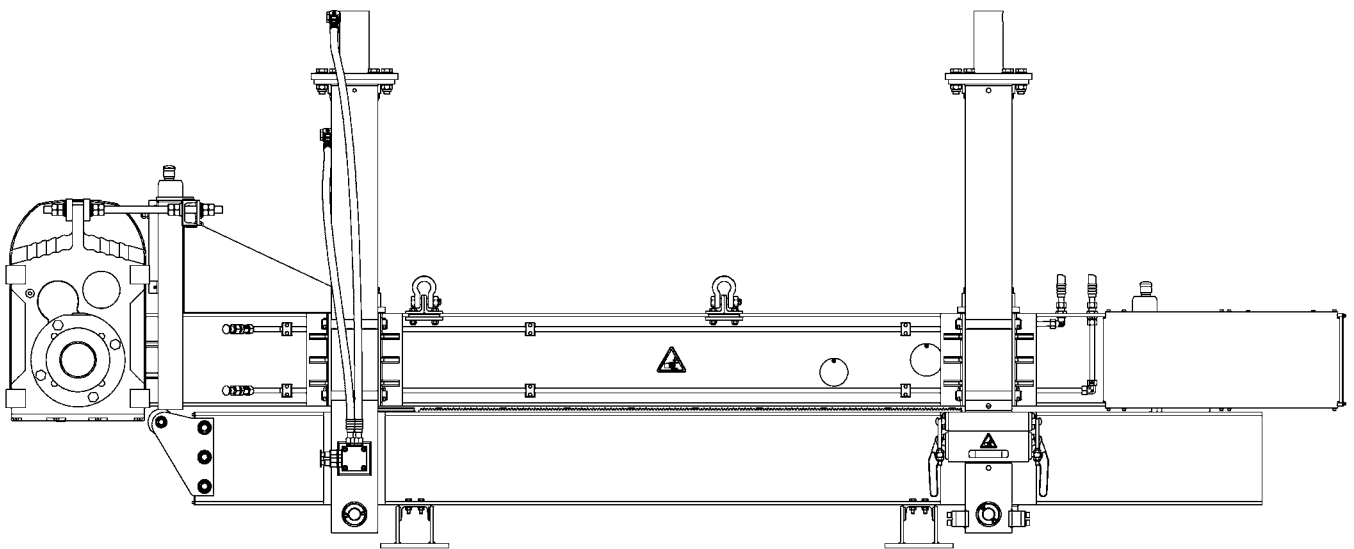

Der Belt Ripper ist für das Trennen von Fördergurten aller Konfektionsarten und Festigkeiten, insbesondere von Stahlseilgurten bestimmt. Der Trennschnitt erfolgt rechtwinklig zur Gurtlaufrichtung.

Der Belt Ripper ist für den stationären und mobilen Einsatz bestimmt. Bei dem stationären Einsatz wird der Gurt-Klemmrahmen parallel geöffnet und der Fördergurt in den Rahmen eingeschoben. Bei dem mobilen Einsatz wird der Gurt-Klemmrahmen am Kran hängend scherenförmig geöffnet und in die Bandanlage eingefahren.

Alternativ kann der Gurt-Klemmrahmen mit anmontierten Radsätzen am Boden stehend scherenförmig geöffnet und in die Bandanlage eingefahren werden.

Der Belt Ripper besteht aus folgenden Komponenten:

- Gurt-Klemmrahmen
- Elektro-Schaltschrank
- Hydraulikaggregat

The Belt Ripper is intended for the cutting of conveyor belts of all assembly types and strengths, in particular of steel cord belts. The ripping cut is made at right angles to the belt running direction.

The Belt Ripper is intended for stationary and mobile use. In the case of stationary use, the belt clamping frame is opened parallel and the conveyor belt is pushed into the belt clamping frame. In the case of mobile use, the belt clamping frame suspended from the crane is opened scissors-like and moved into the belt conveyor.

Alternatively the belt clamping frame standing on the ground with mounted wheelsets can be opened scissors-like and moved into the belt conveyor. For this purpose a rail track is to be provided by the customer.

The Belt Ripper consists of the following components:

- Belt clamping frame
- Electrical switch cabinet
- Hydraulic unit



NILOS

NILOS GmbH & Co. KG
Reisholzstr. 15
40721 Hilden • Germany
Phone: +49 2103 951-0
Fax: +49 2103 951-209
info@nilos.de
www.nilos.de



Belt Ripper

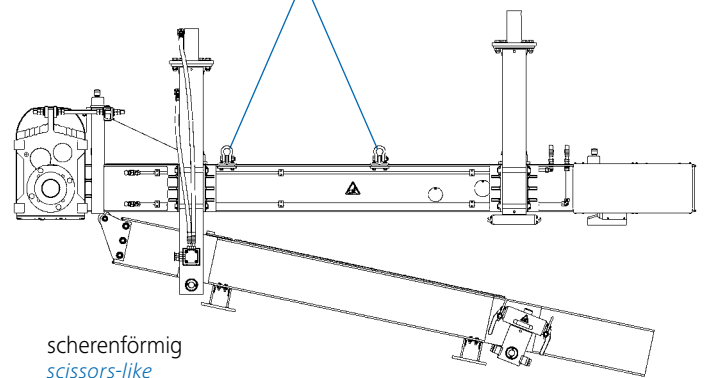
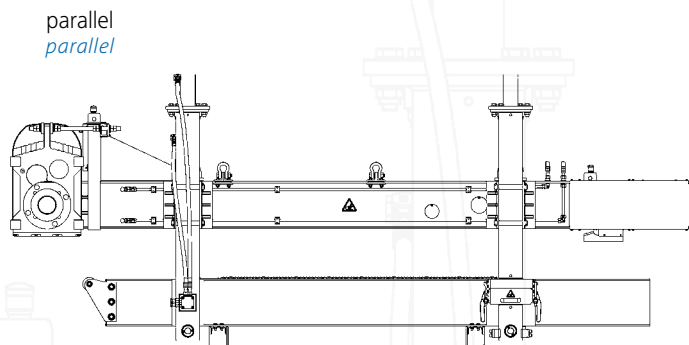

Abmessungen ohne Steuereinheit

Dimensions without control unit

Breite <i>Width</i>	ca. 960 mm <i>approx. 960 mm</i>
Höhe <i>Height</i>	ca. 1750 mm <i>approx. 1750 mm</i>
Länge <i>Length</i>	ca. 2600 mm + Gurtbreite <i>approx. 2600 mm + belt width</i>

Technische Daten

Technical data

Betriebsspannung * <i>Service voltage *</i>	DS 400 V, 50 Hz <i>Three-phase current 400 V, 50 Hz</i>
Antriebsleistung, Trennmesser <i>Driving power, ripping knife</i>	2,2 kW <i>2.2 kW</i>
Antriebsleistung, Pumpenmotor <i>Driving power, pump motor</i>	3,0 kW <i>3.0 kW</i>
Max. Gurtbreite <i>Max. belt width</i>	bis 3200 mm <i>up to 3200 mm</i>
Max. Gurtstärke <i>Max. belt thickness</i>	bis 50 mm <i>up to 50 mm</i>
Trennzeit bei GB 3200 mm <i>Ripping time for belt width of 3200 mm</i>	ca. 140 sek. <i>approx. 140 secs.</i>